

Project Name	
Project #	
Model #	
Type	



ILLUMINATION

- Long lasting, efficient ultra bright white LED lamp heads.
- One 1.1 watt white LED per lamphead.
- Unique all-inclusive lamp, reflector and lens assembly.
- Long life ultra-bright, energy efficient Red or Green LED EXIT sign illumination.

ELECTRICAL

- Dual 120/277 voltage.
- Unique bi-color LED indicator alerts occupant on battery condition (Green-normal, Red-check battery).
- Charge rate/power "ON" LED indicator light and push-to-test switch for mandated code compliance testing.
- 3.6V Long life, maintenance-free, rechargeable NiCd battery.
- Internal solid-state transfer switch automatically connects the internal battery to LED board and LED lamp heads for minimum 90-minute emergency illumination.
- Fully automatic solid-state, two rate charger initiates battery charging to recharge a discharged battery in 24 hours.

MOUNTING

- Mounting canopy included for top or end mount.
- Universal knockout pattern on back plate for wall mount.

STANDARD	CTXTEU	OPTIONAL

HOUSING

- Specification-grade, low profile thin plastic design.
- Patented, field selectable universal single/double face configuration.
- Injection-molded, engineering grade, 5VA flame retardant, high-impact resistant, thermoplastic in white or black finish.
- EZ snap-out Chevron directional indicators.
- Remote capacity of up to 2.0 watts available.

OPTIONS

- HL: Provides increased center-to-center spacing (2.0W per head).

WARRANTY / LISTING

- One year warranty on all electronics and housing. Battery prorated for one year.
- Meets UL924, NFPA 101 Life Safety Code, NEC, OSHA, Local and State Codes.
- UL Listed for damp locations (0°C – 50°C).
- Certified to CEC under Title 20 regulations.

DIMENSIONS

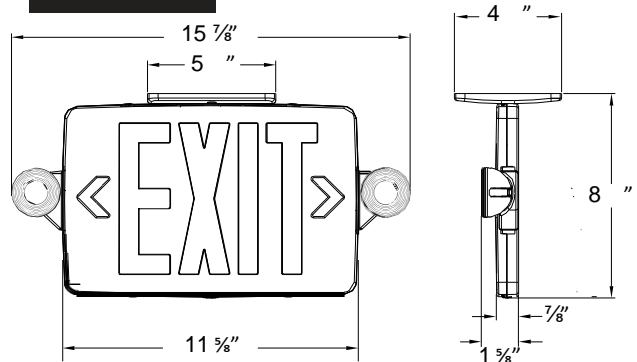

ORDERING INFORMATION

Sample Part Number: CTXTEU3RW

MODEL	No. of FACES	LETTER COLOR	HOUSING COLOR	OPTIONS
CTXTEU	3 Universal Single/ Double Face	R Red G Green	W White B Black	HL High Lumen' RC Remote Capacity'

¹ -HL and -RC cannot be ordered together.