

Project Name	
Project #	
Model #	
Type	

LED LAY IN FPL-115-LR2418XX
FRAME PANEL - CCT & WATTAGE SELECTABLE
1X4', 2X2', 2X4'

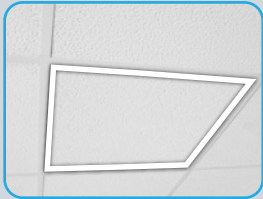

FRAME PANEL IN USE

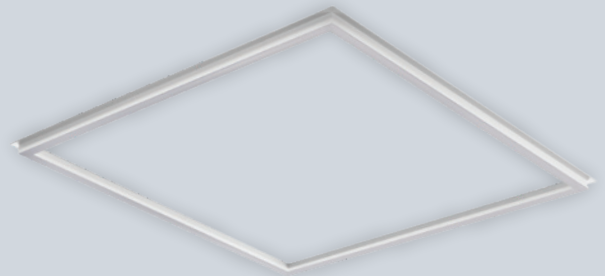

2X2'

20W | 30W | 40W

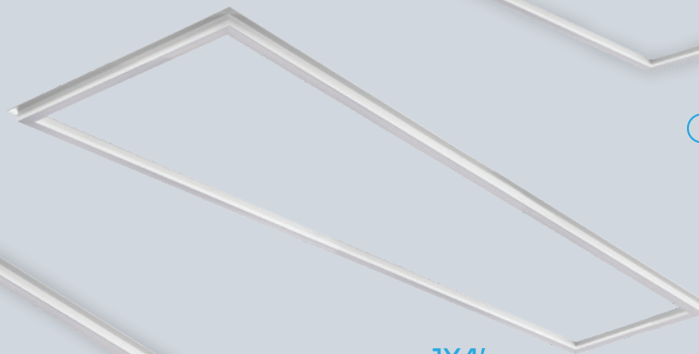

1X4'

20W | 30W | 40W

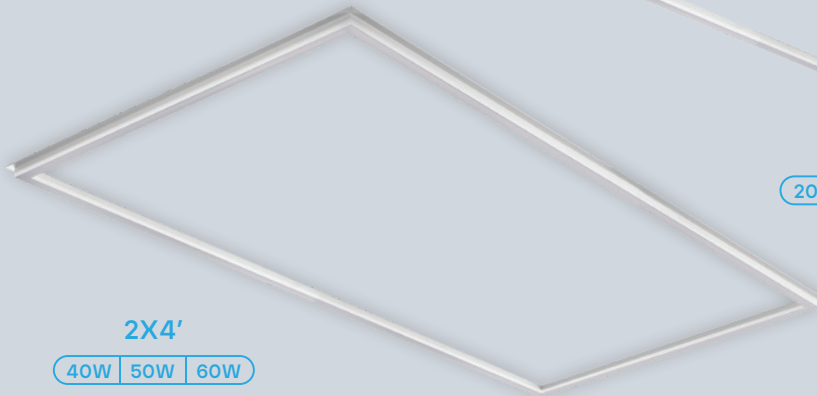

2X4'

40W | 50W | 60W

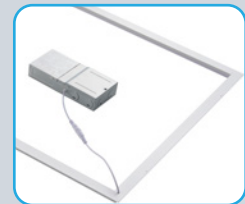

DRIVER WITH CCT & WATTAGE SELECT SWITCH



COLOR SELECTABLE
3000K | 4000K | 5000K

WATTAGE SELECTABLE
3 OPTIONS

DIMMABLE
0-10V

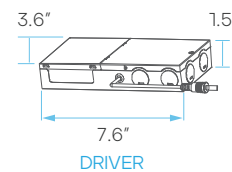
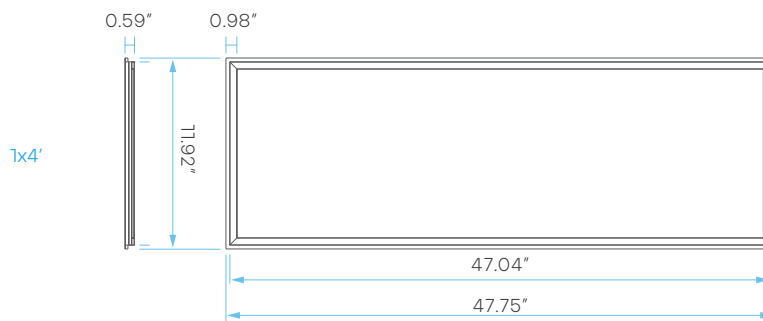

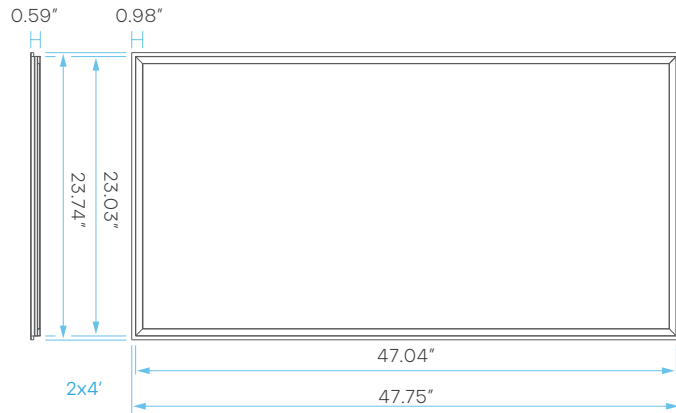
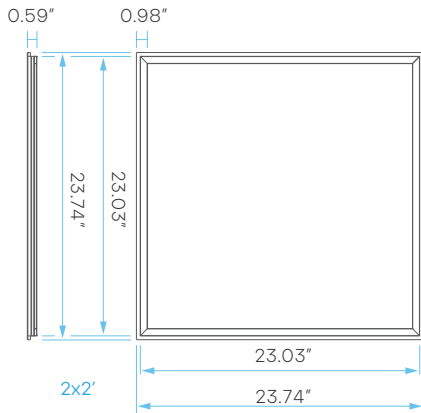

ELECTRICAL

MODEL	DESCRIPTION	POWER	INPUT VOLTS	EFFICACY	LIFETIME
1x4' FPL-115-LR24188	LED1X4FRAME/PNL/3WO/3CCT/D	20	100-277V	125	50,000
		30			
		40			
2x2' FPL-115-LR24185	LED2X2FRAME/PNL/3WO/3CCT/D	20	100-277V	125	50,000
		30			
		40			
2x4' FPL-115-LR24187	LED242FRAME/PNL/3WO/3CCT/D	40	100-277V	125	50,000
		50			
		60			

PHOTOMETRIC

MODEL	DESCRIPTION	COLOR (CCT)	TEMP	LUMEN	FLOOD	CRI	ETL	DLC
FPL-115-LR24188	LED1X4FRAME/PNL/3WO/3CCT/D	3000K/4000K/5000K	CCT SELECT	2500 (@20W)	120°	80	YES	
				3750 (@30W)				
				5000 (@40W)				
FPL-115-LR24185	LED2X2FRAME/PNL/3WO/3CCT/D	3000K/4000K/5000K	CCT SELECT	2500 (@20W)	120°	80	YES	YES
				3750 (@30W)				
				5000 (@40W)				
FPL-115-LR24187	LED242FRAME/PNL/3WO/3CCT/D	3000K/4000K/5000K	CCT SELECT	5000 (@40W)	120°	80	YES	YES
				6250 (@50W)				
				7500 (@60W)				

COMPATIBLE WITH:

LR35124
Emergency LED Driver



LR24183
4' CABLE EXTENDER



2X2 FRAME PANEL CANOPY

COMPATIBLE WITH LR24185

*SOLD SEPARATELY

DESCRIPTION

LED2X2FRAME/PNL/CANOPY



FRAME PANEL CANOPY IN USE