

Project Name	
Project #	
Model #	
Type	

SEN-053-PPU-301 Power Pack & Controller



OVERVIEW

The **SEN-053-PPU-301** is a power pack and controller designed for low voltage lighting control system. It not only supplies 24VDC power for the operation of multiple low voltage occupancy sensors, but also provides line voltage load switching in response to signals from the connected low voltage occupancy sensors or control devices. The unit can be attached to a junction box through a ½ inch knockout with the designed threaded nipple and locknut.

It may also be mounted into fixture cable trays or located inside an adjacent junction box for specific local code requirements.

The **SEN-053-PPU-301** is an isolated class 2 switching mode power supply device for parallel sensor connection up to maximum 150mA capacity. With proper wiring connection, the load can be turned ON and OFF automatically based on inputs from occupancy sensors or other control devices.

Various control modes can be achieved with different wiring connections. Only basic wiring diagrams are illustrated. Consult with an IR-TEC team member if a more complex wiring diagram is required.

FEATURES

- Class 2 switching mode power supply
- 120/277VAC universal voltage power
- 24VDC, 150mA power supply output
- DC and relay status LED indications
- Control up to 20A of load capacity
- Zero crossing relay switching circuitry
- Low voltage DC over current protection
- Versatile energy efficient load control

APPLICATION

Light Control

HVAC Control

The **SEN-053-PPU-301** can be applied to control lighting circuits, motors, self-contained air conditioners, VAV systems, fans and motorized damper controls. It is ideal for any application which requires line voltage switching with low voltage control input. By connecting this power pack with low voltage sensors, or other devices, various control configurations can be easily achieved.

SPECIFICATIONS

Power Supply	120/277VAC, 50/60Hz
DC Output	24V, 150mA max.
Control Input	Control, Active Low
Load Control	Ballast-20A, 120/277VAC
	Resistive-20A, 120/277VAC
	Motor-1 Hp, 120/240VAC
Humidity	95% RH max.
Temperature	-4°F~122°F (-20°C~50°C)
Dimensions	3"x1.8"x1.8" (75x45x45mm)

SEN-053-PPU-301

Power Pack & Controller

INSTALLATION NOTES

- The SEN-053-PPU-301 should be installed in accordance with local, state or national electrical codes.
- Most applications require UL-listed cables in proper gauge. Consult qualified electrician for correct wiring gauge.

WIRING DIAGRAMS

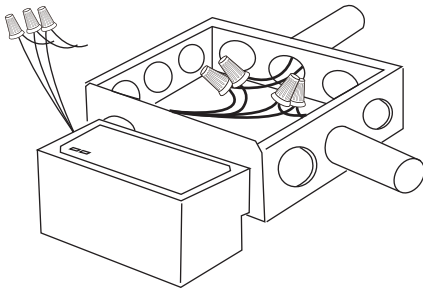

Line voltage wiring connection should be made inside of junction box.

Sensor control ON/OFF

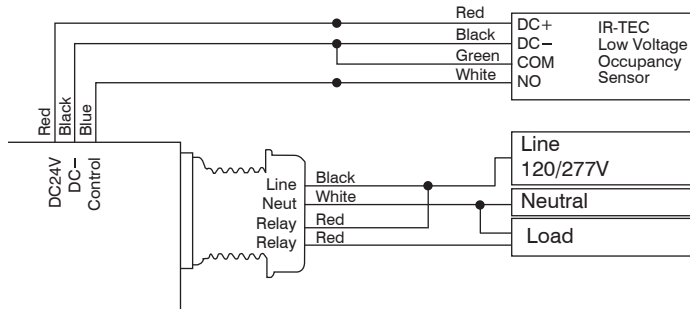

Sensor control ON/OFF, Receptacle Control

