

Project #	
Model #	
Type	

SEN-053-LPS-509
series

TRANS

EO



OVERVIEW

The SEN-053-LPS509 series member of the TRANS family is a line voltage daylight sensor designed for automatic daylighting control. This sensor is able to continuously measure the ambient light level in the controlled area and respond with switched line voltage output to control the connected lighting accordingly.

This daylight sensor employs a cutting edge digital ambient light sensor (ALS) with an advanced algorithm to provide closed loop, dynamic ambient light level sensing capability. When the ambient light level is lower than the ON setpoint, the sensor will activate its relay contacts to turn the connected light on automatically. The sensor will turn the light off automatically if the ambient light level is higher than the OFF setpoint for a period of time. An exclusive Hybrid Switching technology makes LPS-509 series ideal to control the lighting with exceptionally high inrush current (HIC) while switching on, such as multiple LED or CFL lightings connected in parallel.

The innovative Accu-Set digital potentiometer makes the on/off threshold and switch-off delay time settings easier, faster and more accurate than conventional potentiometer. Like all sensors in the TRANS family, the LPS-509 series is also available in various mounting options. This feature offers a second-to-none design and installation flexibility for daylight harvesting and control applications in sustainable buildings.

FEATURES

- Digital data control ambient light sensor
- Human-eye matching spectral response
- Sudden bright light filter to avoid cycling
- 120/277VAC multi-voltage power operation
- True zero-cross hybrid switching control
- 7 levels of on & off thresholds selectable
- 7 different light-off delay times selectable
- Available with variety of mounting options

APPLICATION

The SEN-053-LPS-509 series daylight sensor can be used in various applications to meet the requirements for daylight harvesting in areas defined as daylight control zones.

- Educational Industrial/retail Public Buildings
- Commercial
-
-



All of the products and specifications can change without prior notice

Please note this specification sheet is considered to be business promotional material and not used for product listing identification purposes

SEN-053-LPS-509 series

Line Voltage Daylight Sensor

TRANS

OPERATIONS

The SEN-053-LPS-509 series is a line voltage daylight sensor to provide switched line voltage for automatic daylighting control. The sensor can be applied to control lights in areas that receive sufficient daylight, thus the electric lights can be automatically switched off. The relay contacts will be engaged when the ambient light level is lower than the ON setpoint, and disengaged if the ambient light level is higher than the OFF setpoint for a period of time.

Following table indicates the day/night thresholds and light-off delay time of various potentiometer positions for control setting reference.

Position	1	2	3	4	5	6	7
LUX	10	20	40	60	80	200	400

Above light level values are reference measured at 3 ft. high from the floor with sensor installed at 10 ft high ceiling.

TIME

Position	1	2	3	4	5	6	7
Delay	T	1'	3'	5'	10'	20'	30'

The delay time will return to the factory default setting after 10 minutes if the TIME pot is set at T position permanently.

Mounting Options The SEN-05-LPS-509 series can be mounted into the ceiling, attached to a fixture or mounted into a junction box to control the connected lighting. The mounting options are available by combining a specific mounting bracket from the chart below. The bracket will be shipped with the sensor when ordered with the respective code. Mounting option code F and W allow the LPS-509SX sensor to be directly integrated with OEM light fixture for indoor or wet location.

Code	Mounting Option	Mounting Bracket
F	Fixture Integrated	---
W	IP-66 Fixture Integrated	---
E	Fixture External	EMB-500
P	IP-66 Fixture External	PMB-500
S	Ceiling Surface	SMB-500
C	Junction Box	CMB-500

Wiring Diagram

Basic wiring diagrams are included for general reference. Consult with an IR-TEC team member if a more complex wiring diagram is required.

A. Single sensor control

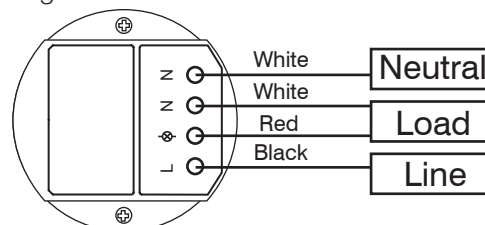

B. Multiple sensors control

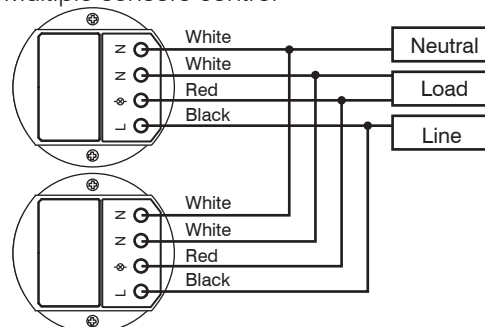

SPECIFICATIONS

Power supply	120/277VAC, 50/60 Hz
Sensing device	Digital data control ambient light sensor
Sensor output	Switched line voltage
Maximum Load @ -40°F~131°F (-40°C~55°C)	Incandescent/Halogen – 800/1200W(VA)@120/277V
	Fluorescent Ballast/CFL – 800/1200W(VA)@120/277V
	Ballast Electronic (LED) – 540/1200VA@120/277V
Maximum Load @ 131°F~158°F (55°C~70°C)	Incandescent/Halogen – 500/750W(VA)@120/277V
	Fluorescent Ballast/CFL – 500/750W(VA)@120/277V
	Ballast Electronic (LED) – 500/750VA@120/277V
Load switching	Hybrid switching
Inrush current	Max. 80A for 16.7mS
Sensing range	Approx. 0.2~200 fc (2~2,000 lux)
Mounting height	8 - 12 ft. (2.4-3.6 m)
Field of view	Approx. 80°
Switch-off delay	T/1'/3'/5'/10'/20'/30', T<30 sec. for testing
ON/OFF threshold	7-level Accu-Set digital potentiometer
Op. humidity	Max. 95% RH
Op. temperature	-40°F~158°F (-40°C~70°C)
Dimensions	Ø2.56" x H1.77" (Ø65 x H45mm)

All of the products and specifications can change without prior notice

Please note this specification sheet is considered to be business promotional material and not used for product listing identification purposes